

VISIONSCAPE® GIG E



Integrated GigE Vision Solution

From an economical single camera system to a sophisticated eight camera application, Microscan's Visionscape GigE Solution contains all necessary components for a complete, successful machine vision implementation.

PC-based Gigabit Ethernet systems leverage standard network components such as cabling, switches and interface cards. Visionscape GigE supports a complete set of Microscan machine vision GigE cameras which, in combination with Visionscape software, allows for rapid deployment of any scale of machine vision solution.

Visionscape GigE: At a Glance

- High speed, high resolution image processing
- Provides full capabilities of powerful Visionscape software
- System implementation uses standard network components
- Support up to eight Visionscape GigE cameras
- GigE cameras available in multiple configurations:

- VGA MONO CMOS** (Color Optional)
- VGA MONO CCD** (Color Optional)
- VGA MONO CCD POE** (Power Over Ethernet)
- XGA MONO CCD**
- SXGA MONO CCD** (1.3 Megapixel)
- UXGA MONO CCD** (2 Megapixel)
- QSXGA MONO CCD** (5 Megapixel)

For more information on this product, visit www.microscan.com.

Visionscape GigE: Capabilities

- Linear Barcodes 
 - Image processing
 - Image analysis & feature extraction
- 2D Symbols 
 - Flaw detection
 - Object location
- OCR/OCV ABC123 
 - Dimensional measurements
 - Custom processing options

Gigabit Ethernet (GigE)

Gigabit Ethernet allows for high speed data transfers at one gigabit per second. With the Visionscape GigE solution, this system can be easily deployed using standard low-cost network components, long cable lengths and no frame grabber boards.

Flexible Configuration

The Visionscape GigE camera features C-mount optics, built-in strobe and trigger connections and optional Power over Ethernet (PoE). A wide variety of sensor resolutions are available, ranging from VGA to QSXGA (5 MP), with CMOS, CCD and color options.

Compact and Lightweight

The Visionscape GigE camera weighs just 4 oz. and its small form factor allows for flexible positioning in tight spaces or mounting in robotic applications.

User Interfaces

Visionscape FrontRunner engineering user interface enables quick and easy creation of complex vision applications. The AppRunner runtime interface provides complete system status, application monitoring and results.

Application Examples

- Assembly verification (automotive, medical devices, packaging)
- Print quality inspection (pharmaceutical, other)
- Package quality inspection (food and beverage)
- Component presence/absence checking (electronics)
- Part location (robotics, machine builder)
- Part identification (automotive, electronics, packaging)

Specifications for Visionscape GigE PC

MINIMUM PC REQUIREMENTS:

- Pentium P4 class PC (2.4 GHz or higher)
- Windows XP (SP2 or later), Windows Vista
- 1 GB minimum RAM
- XGA display (True Color or 64K)
- Open PCIe slot for Digital IO card – if required
- Built-in GigE network card or open slot for GigE NIC

Specifications for Visionscape GigE Camera

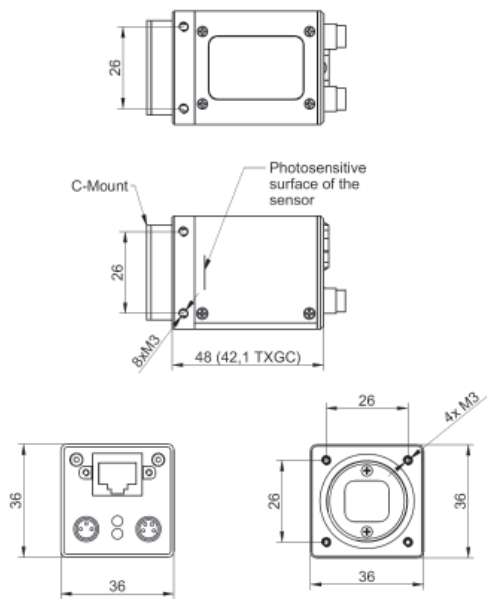

CONNECTORS

No.	Function
1	RJ45 Gigabit Ethernet
2	M8-3 Power
3	M8-4 Trigger & Strobe

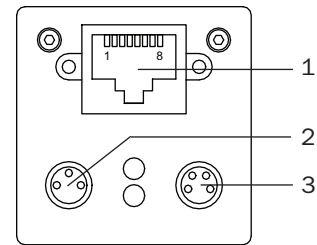

CONFIGURATIONS

Visionscape GigE Camera Model	Resolution	Sensor Size	FPS
VGA Mono CMOS, CMGC03	752 x 480	1/3"	60
VGA Color CMOS, CMGC03c	748 x 476	1/3"	60
VGA Mono CCD, CMG03	656 x 494	1/3"	90
VGA Color CCD, CMG03c	656 x 490	1/3"	90
VGA Mono CCD (1/2" Sensor), CMG04	656 x 494	1/2"	57
XGA Mono CCD, CMG08	1032 x 776	1/3"	28
SXGA Mono CCD, CMG13	1392 x 1040	1/2"	20
UXGA Mono CCD, CMG20	1624 x 1236	1/1.8"	16
QSXGA Mono CCD, CMG50	2448 x 2050	2/3"	15
VGA Mono CCD POE, CMG03-P	656 x 494	1/3"	90

MECHANICAL

- Height:** 1.42" (36 mm)
- Width:** 1.42" (36 mm)
- Depth:** 1.66" (42.1 mm)
- Weight:** 4.0 oz. (115 g) with tripod mount

COMMUNICATION PROTOCOLS

Interfaces: Gigabit Ethernet

LIGHT COLLECTION

Progressive scan, full frame and partial frame

ELECTRICAL

- Power:** 8 VDC at 370 mA to 30 VDC at 120 mA
- Power Consumption:** 3.5 W

ENVIRONMENTAL

- Operating Temperature:** 5° to 50° C (41° to 122° F)
- Storage Temperature:** -10° to 70° C (-14° to 158° F)
- Storage:** Up to 90% (non-condensing)

SYMBOLGY TYPES

- 2D Symbologies:** Data Matrix, PDF417, QR Code
- Linear Barcodes:** Code 39, Code 93, Code 128, UPC/EAN, UPC-E, UPC Supplementals, I2 of 5, BC412, Codabar, Postnet, Pharmacoce, GS1 Databar and Composite

SAFETY CERTIFICATIONS

FCC, CE

ROHS/WEEE COMPLIANT

ISO CERTIFICATION

Certified ISO 9001:2008 Quality Management System

©2010 Microscan Systems, Inc. SP062C 02/10
 Performance data is determined using high quality Grade A symbols per ISO/IEC 15415 and ISO/IEC 15416 in a 25°C environment. For application-specific results, testing should be performed with symbols used in the actual application. Microscan Applications Engineering is available to assist with evaluations. Results may vary depending on symbol quality. **Warranty**—One year limited warranty on parts and labor. Free extended 3 year warranty upon online product registration.

MICROSCAN®

Microscan Systems Inc.
 Tel 425 226 5700 / 800 251 7711
 Fax 425 226 8250

Microscan Europe
 Tel 31 172 423360 / Fax 31 172 423366

Microscan Asia Pacific
 Tel 65 6846 1214 / Fax 65 6846 4641

www.microscan.com
 Product Information: info@microscan.com
 Auto ID Support: helpdesk@microscan.com
 Vision Support: visionsupport@microscan.com
 NERLITE Support: nerlitesupport@microscan.com